

Step 0.

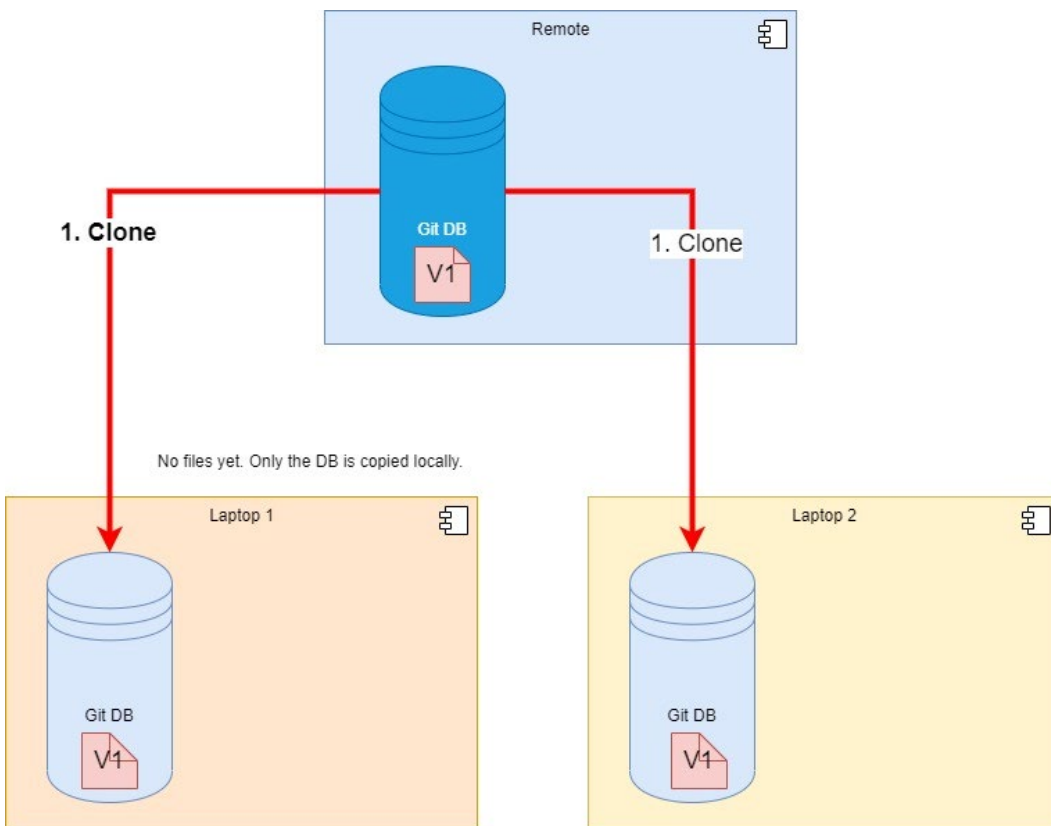

Step 1 – Clone.

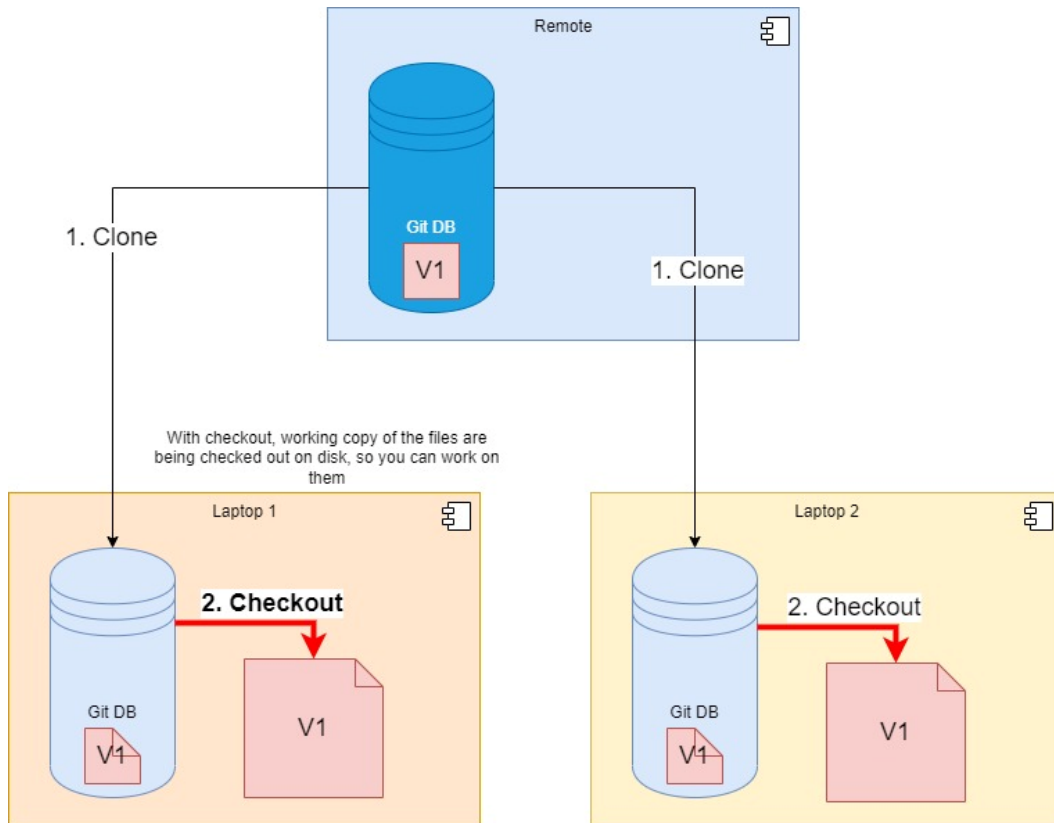

Step 2 – Checkout

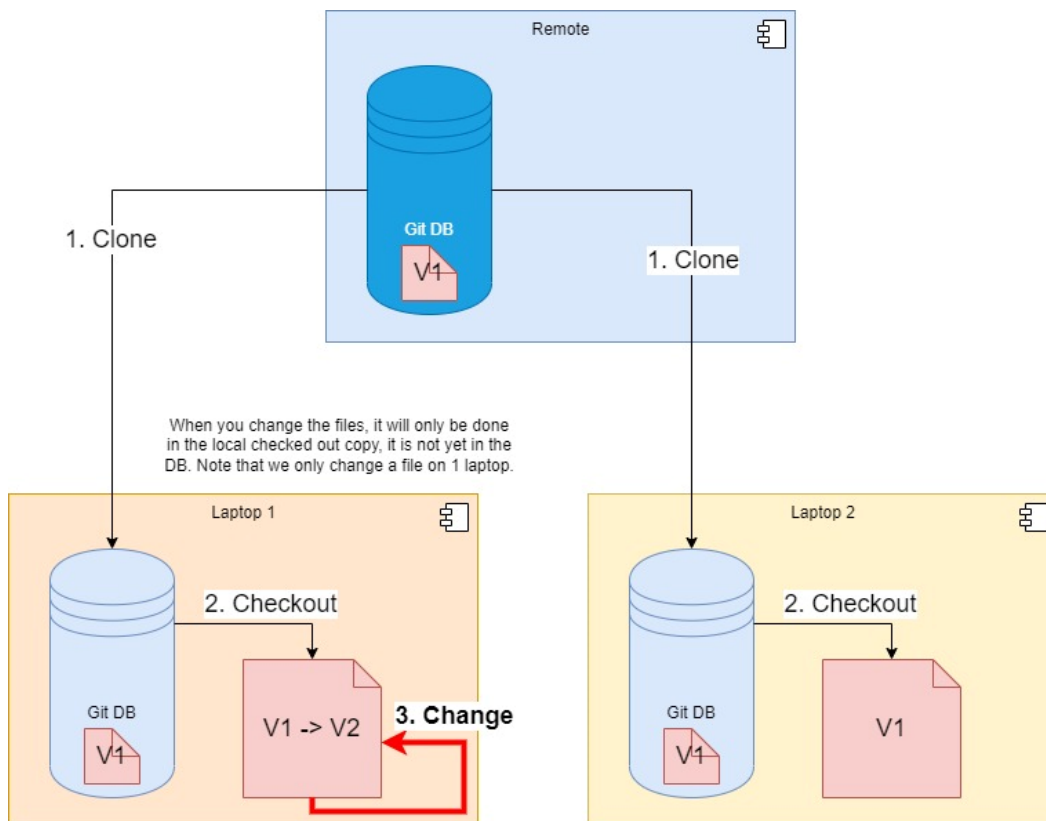

Step 3 – Change

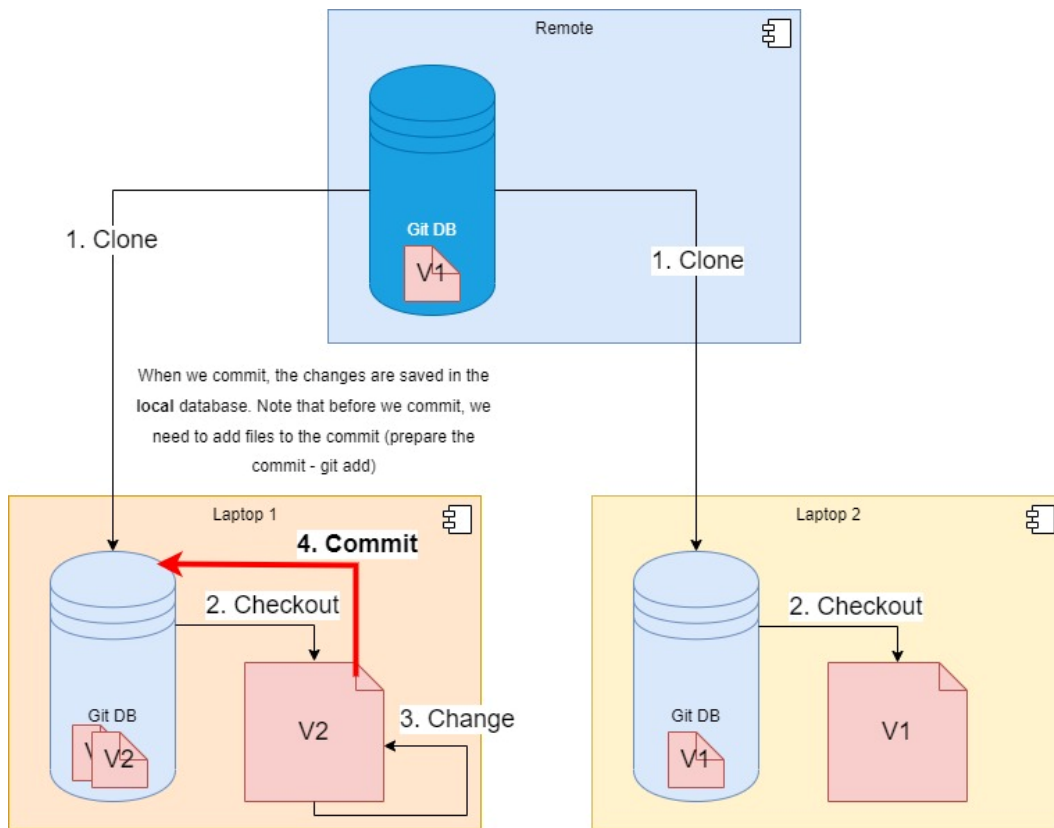

Step 4 – Commit

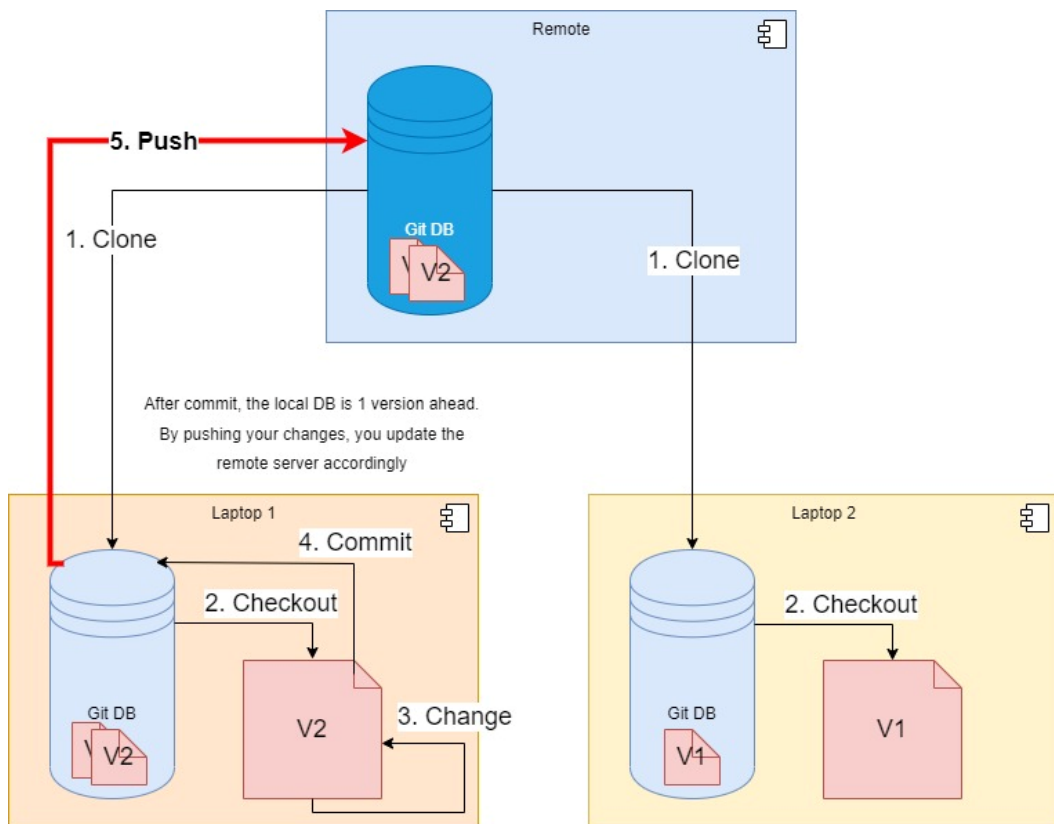

Step 5 – Push

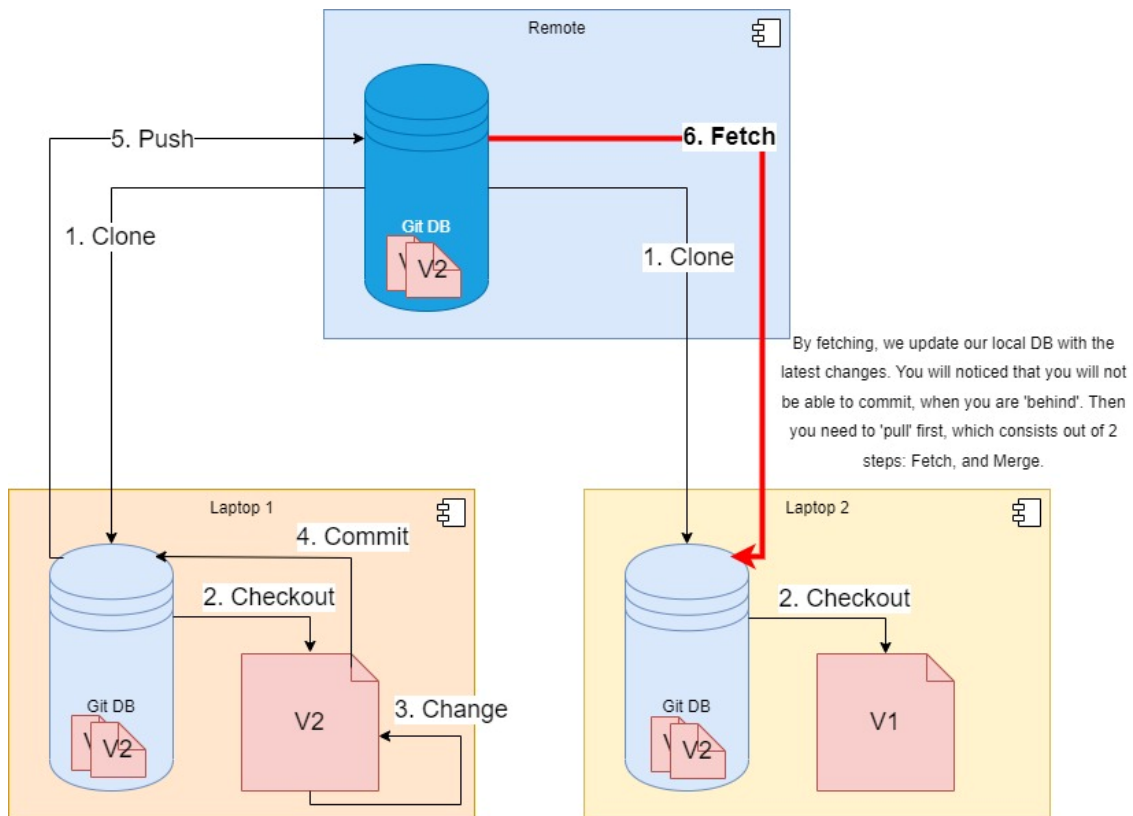

Step 6 – Fetch

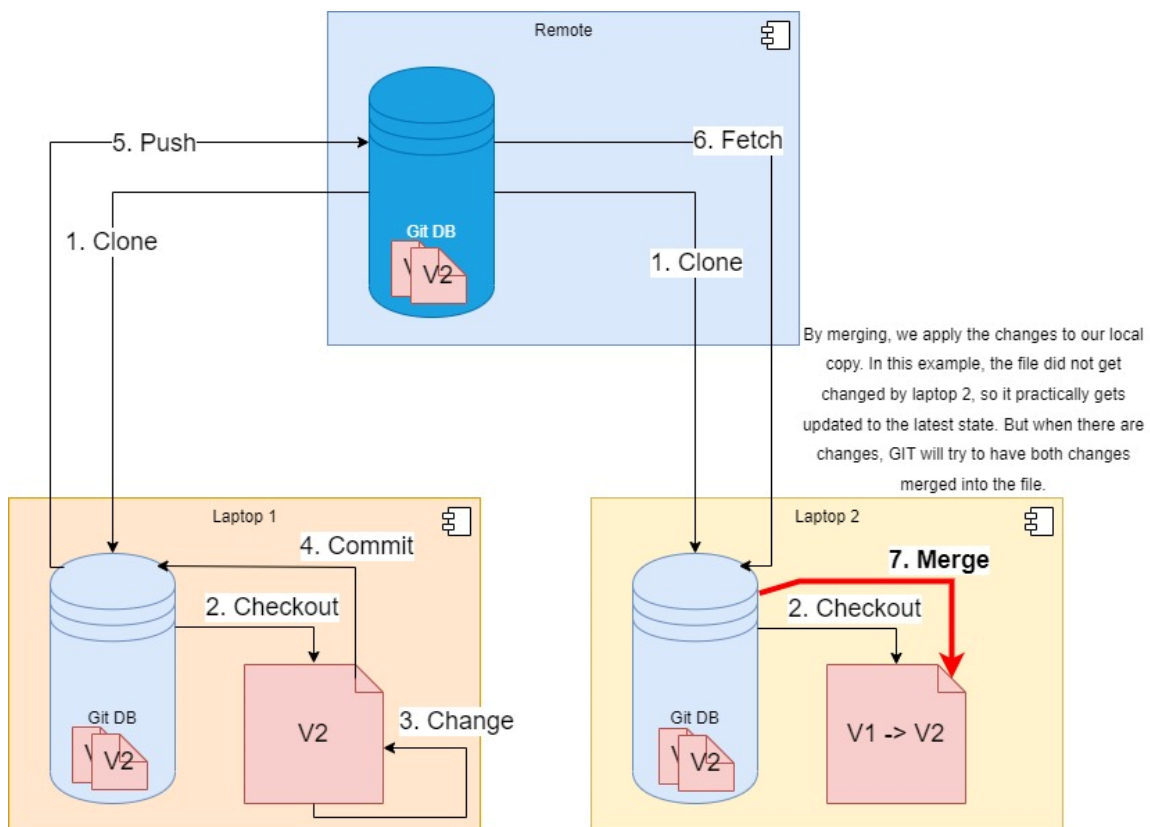

Step 7 – Merge

Steps 6 and 7, can be done in 1 command, being the pull.

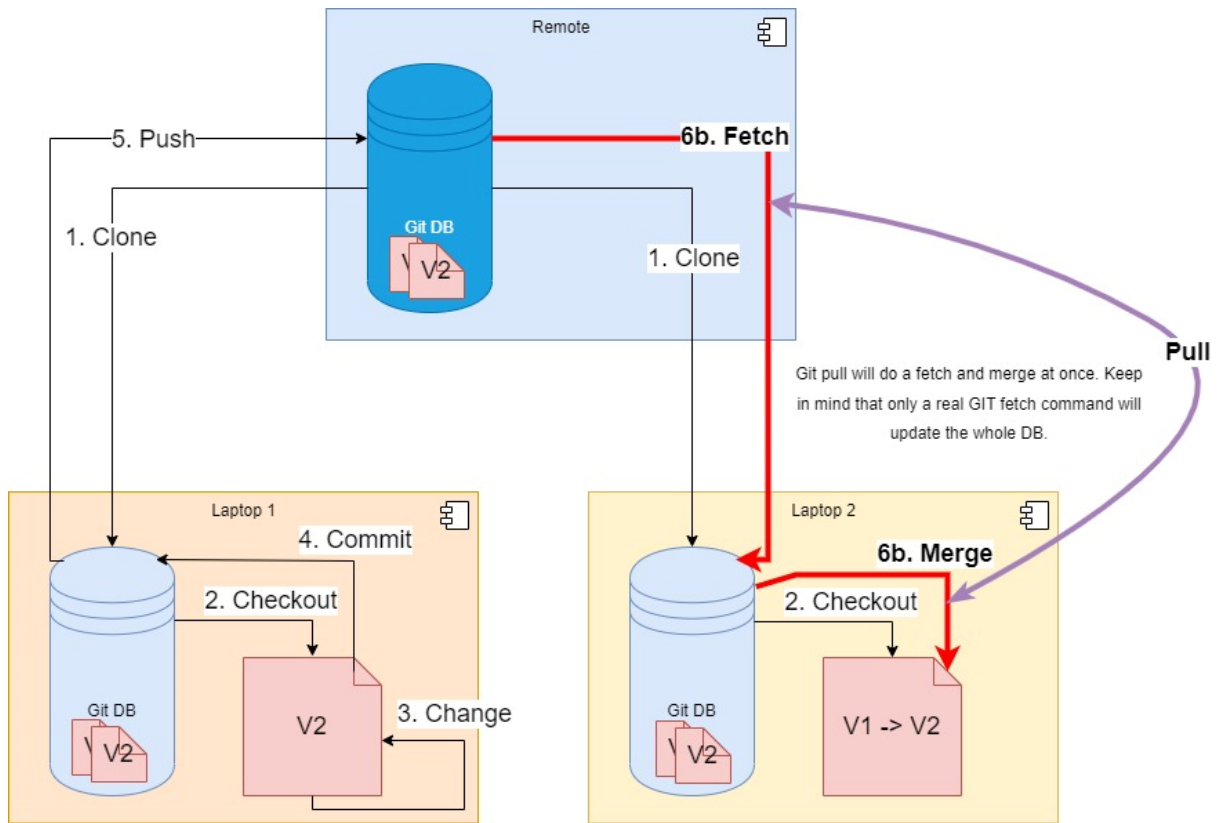

Step 6b – Pull. This is an alternative step 6, that replaces 'Step 6 – Fetch' and 'Step 7 – Merge'